

DRAWING NUMBER		4
TOLERANCE FOR METAL		
DIVISION	DIMENSION	TOLERANCE
-3		±0.05
3-6		±0.05
6-30		±0.10
30-120		±0.15
120-400		±0.20
400-1000		±0.30
1000-2000		±0.50

REVISIONS				
REV	ZONE	DESCRIPTION	ECR	CHECKED

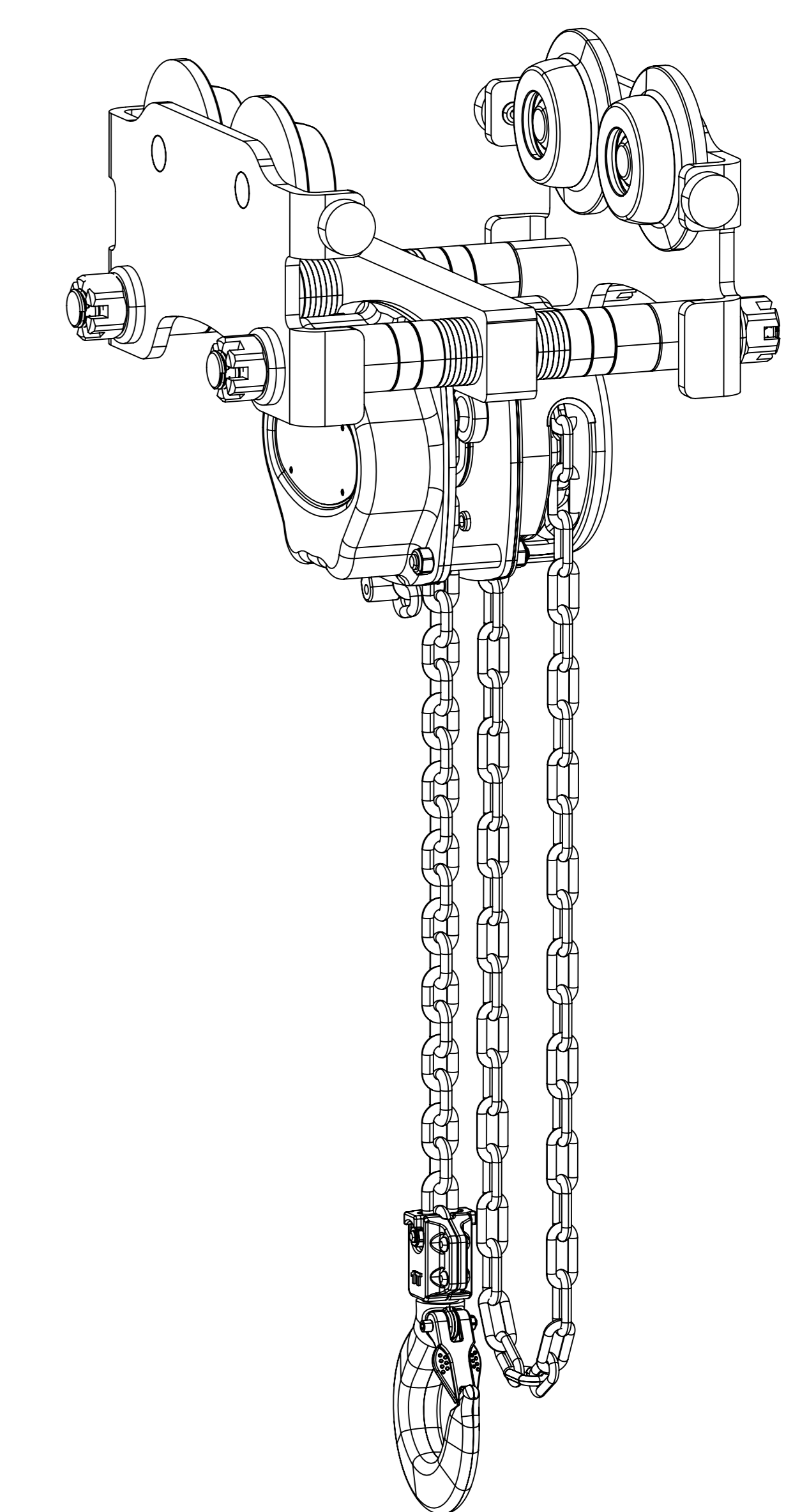

- NOTES
- LHT-H-010L, RATED CAPACITY 1.0T.
  - FLANGE WIDTH 64-203mm, MAX. FLANGE WIDTH 305 CAN BE MADE.
  - HAND CHAIN SPEC. 5X25mm. THE MIN HEADROOM 319mm.
  - SHAFT DIA.=24mm. THK25mm SLEEVE 4PCS, THK13mm SLEEVE 8PCS, THK3mm SLEEVE 28PCS.

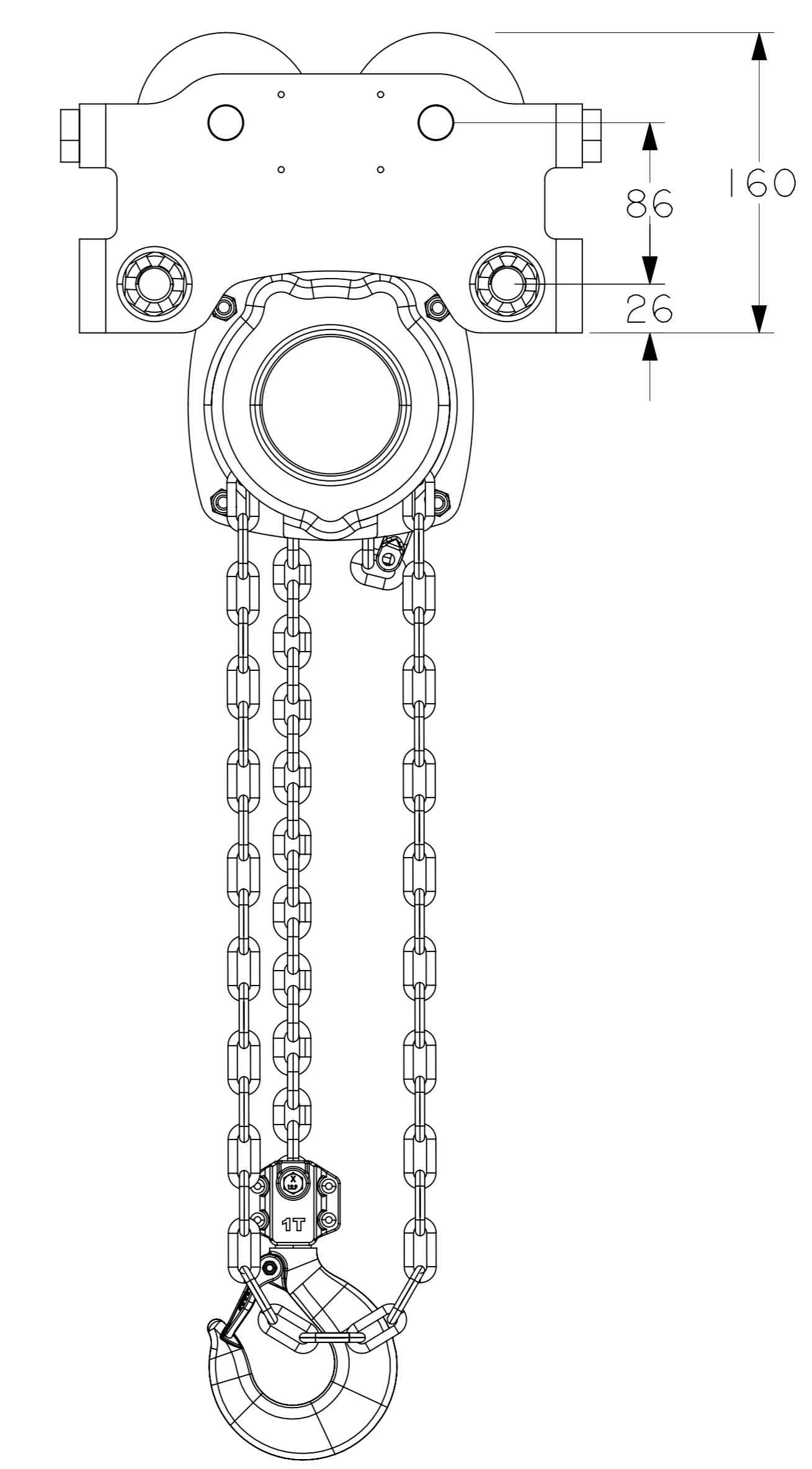
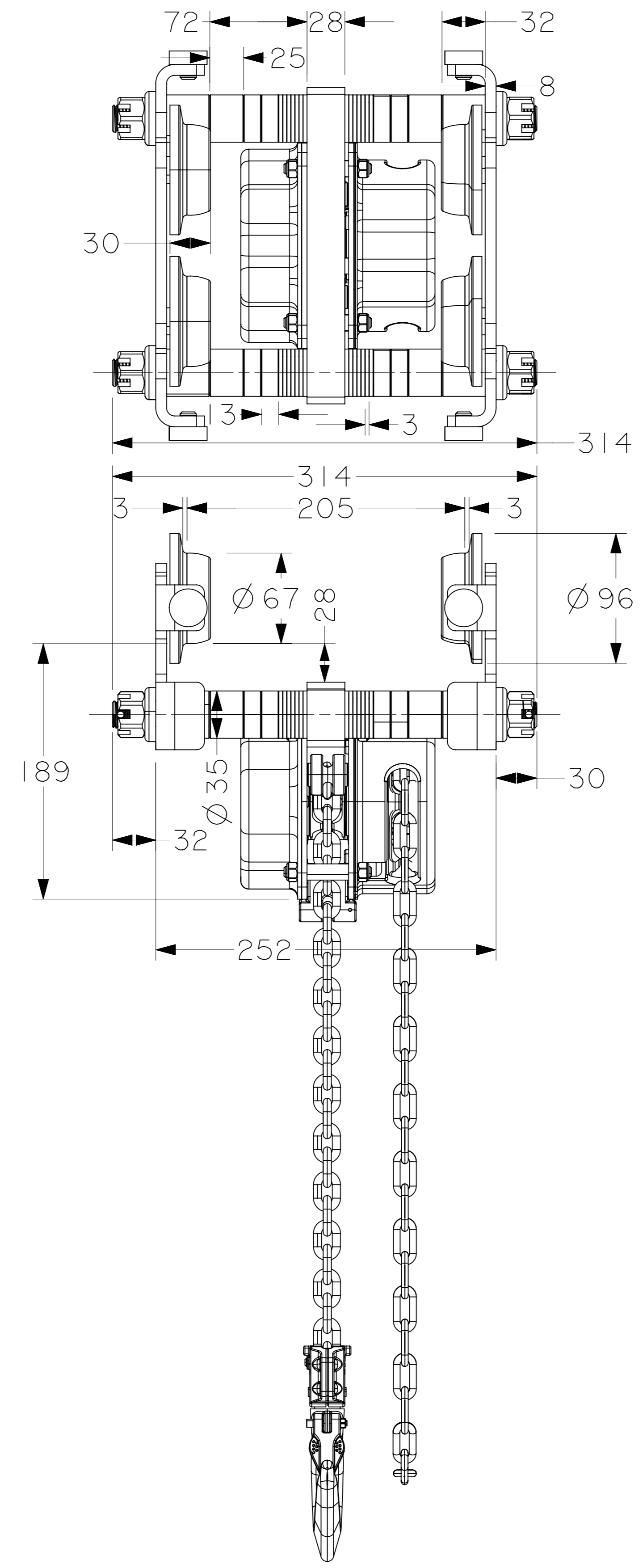
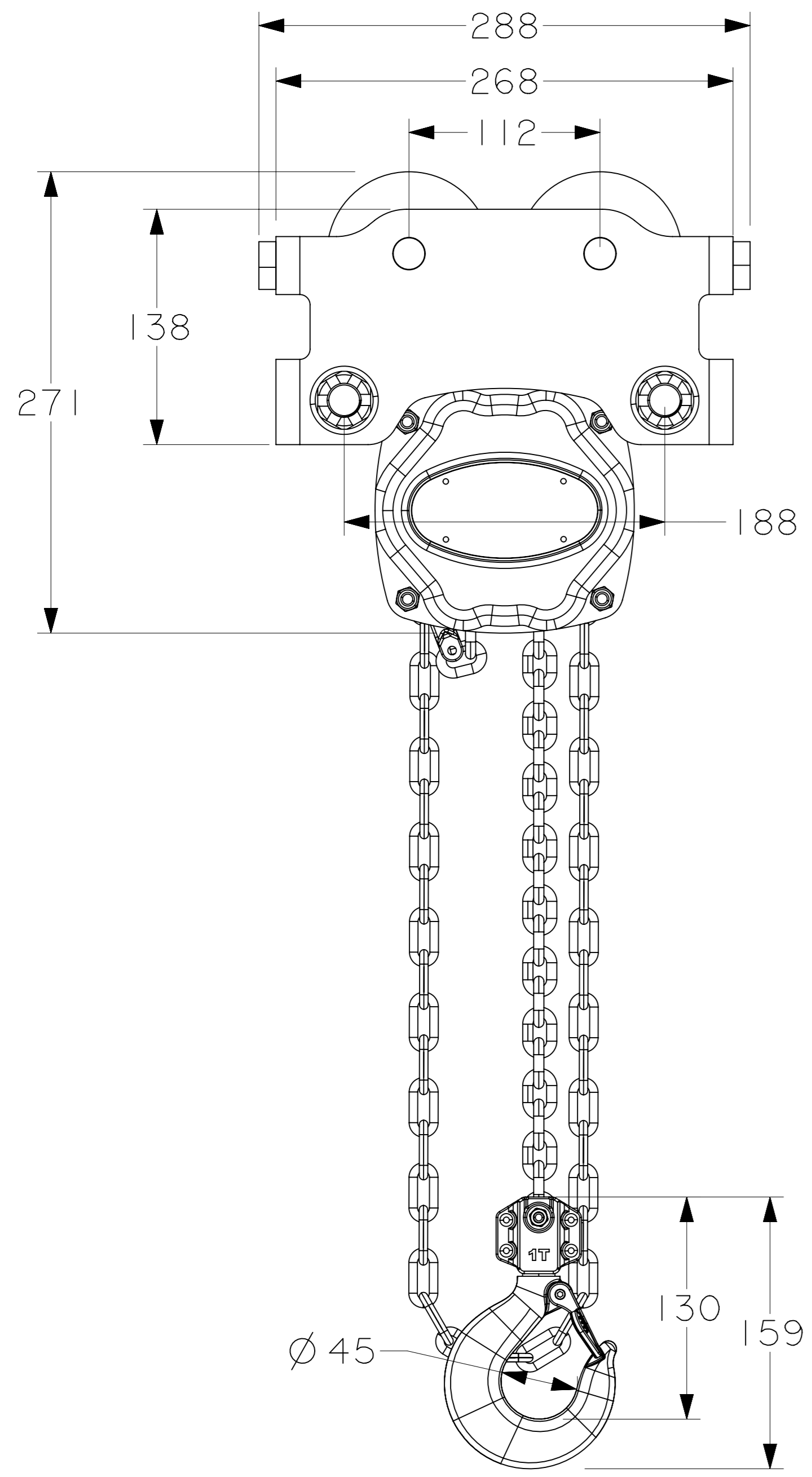
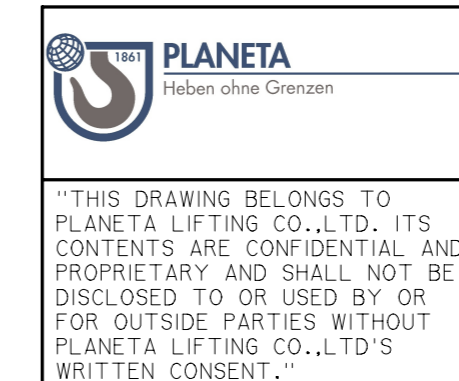

UNLESS OTHERWISE SPECIFIED DIMENSIONS ARE IN MILLIMETERS. FOR ALL UNSPECIFIED DIMENSIONS PLEASE REFER TO THE CAD FILE. DO NOT SCALE. USE DIMENSIONS ONLY. DIMENSION & TOLERANCE PER DIN ISO 2768-F

DRAWN BY	DATE	PLANETA LIFTING CO.,LTD	
JACKY	19/06/06	LHT-H-010L 1.0T	
CHECKED BY	DATE	REV	
APPROVED BY	DATE	SIZE	4
MATERIAL	NA	DRAWING NUMBER	01
FIRST ANGLE PROJECTION	SCALE	NA	SHEET 1 OF 1